



TekTherm™ AK-FR

A2 Fire-Rated Structural Thermal Break

Material Specification

TekTherm™ AK-FR Thermal Breaks are designed to be A2 Fire Rated as well as having a high compressive strength and low thermal conductivity. Compliant for use in buildings above 18m under Document B Building Regulations, this material allows specifiers to meet multiple requirements in one.

TekTherm™ AK-FR has been independently tested and meets A2,s1,d0 (Full laboratory report available on request). We can supply this as cut pads, strips or in any other shape within the parameters of the material.

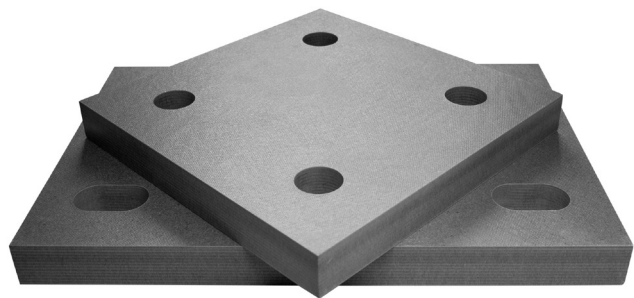

Applications

- Steel to Steel
- Steel to Concrete
- Concrete to Concrete
- Steel to Timber
- Balconies
- Canopies
- Brise-soleil
- Roof Plant enclosures
- Façade Systems
- Balustrading
- Parapets
- Man-safe systems
- Staircases
- Building Maintenance Units

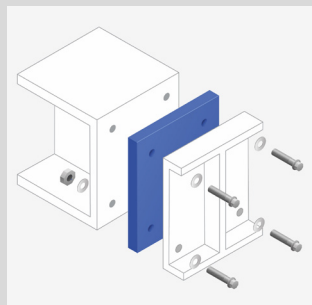

Steel to Steel Connection

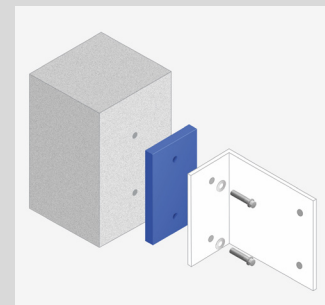

Brickwork to Cladding Connection

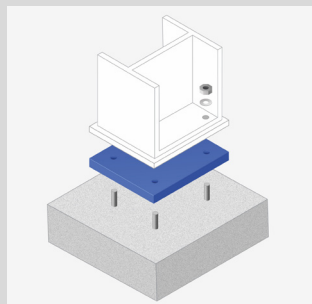

Column Base Connection

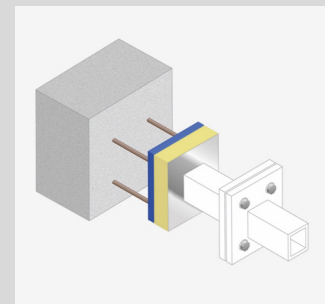

Steel to Concrete Connection



+44 (0)800 6444 949

+01 (951) 519-9855

+353 (0)1 401 6554

info@thermal-breaks.co.uk

info@thermal-breaks.us.com

info@sitetech.ie

Compressive Strength at 23°C (73°F)	Unit	Value	Test Standard
Characteristic	MPa (PSI)	384.0 (55,694)	ISO 826
Design	MPa (PSI)	320 (46,412)	ISO 826

Mechanical Properties

Flexural Strength	MPa (PSI)	165 (23,931)	ISO 178
Modulus of Elasticity	MPa (PSI)	9000 (1,305,340)	ISO 178
Coefficient of Friction (Static)	/	0.33/0.35	ASTM D1894

Physical Properties

Density	g/cm ³ (lbs/ft ³)	2.15 (+/-0.1) (134)	ISO 1183
Water Absorption 24h 23°C (24h 73°F)	%	<1	ISO 12087

Thermal Properties

Operating Temperature	°C (°F)	-100/ +500 (-148 +932)	
Coefficient of Linear Expansion //	1.0E-6 / K	10	DIN 53752
Thermal Conductivity	W/m.K (BTU/Hr/ft2/in/°F)	0.25 (1.73)	DIN 52612
Flame Retardancy		A2,s1,d0	EN 13501-1

Thicknesses Available	mm (")		
		5 (0.196)	
		6 (0.236)	
		10 (0.393)	
		15 (0.59)	
		20 (0.787)	
		25 (1)	

Supply Chain Responsibilities

- Thermal Modelling – Architect
- Structural Evaluation – Structural Engineer
- Cost Evaluation – QS
- Installation – Contractor

Quotations

The below information is required for quotations

- Material spec - TekTherm™ AK200, AK300HT or AK-FR
- Pad dimensions
- Thickness
- Number and size of holes
- Quantity
- Delivery Address

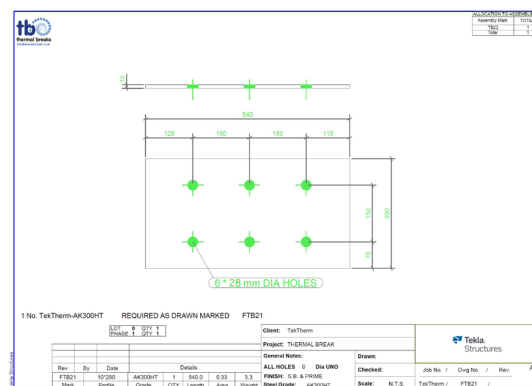

RoHS Directive

Hazardous products listed in the EU-directive 2011/65/EU (ROHS-directive), §4 section 1, are not used as ingredients in this material.

Benefits

- A2,s1,d0 Fire Rated
- Asbestos free
- Low heat conductivity
- Excellent tolerances with respect to parallelism
- Long life expectancy > 50 years (dependent on operating conditions)
- Low water absorption
- Good hydrocarbon stability
- Good chemical stability
- Excellent mechanical durability
- Very good electrical properties

We aim to deliver all orders within 5 working days however we are well versed with industry requirements and therefore will always turn these around in the shortest time possible. Please call us if you have an urgent requirement and we will arrange your order to be expedited.

On and Off-Site Support

We are here to discuss your application and assist you in selecting the right thermal break materials to meet your project specification.

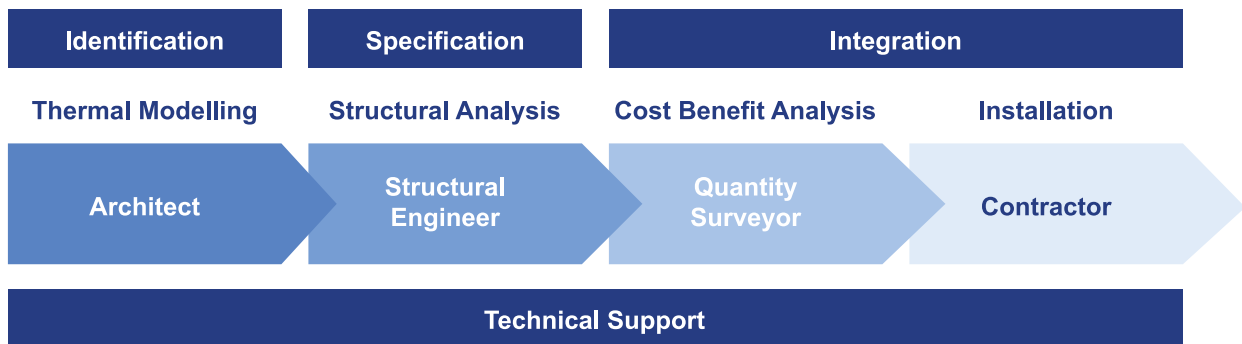

Tekla Plugin available for Thermal Breaks Ltd.

This plugin tool provides easy and efficient design and detailing of our Thermal Break plates within structural steel framed buildings.

Available from <https://thermal-breaks.group>

Updated 23/02/2022



+44 (0)800 6444 949

+01 (951) 519-9855

+353 (0)1 401 6554

info@thermal-breaks.co.uk

info@thermal-breaks.us.com

info@sitetech.ie